



# REDEFINING SELF-SERVICE TECHNOLOGY FOR HEALTHCARE CHECK-IN

## CHICAGO—FOR HEALTHCARE CHECK-IN INNOVATIVE AND INCLUSIVE

The Chicago kiosk represents a leap forward in healthcare check-in technology to provide an improved user experience for all. Available in three easy-to-deploy models, the Height Adjustable (HA), the Freestanding (FS), and the Desktop (DT), the Chicago combines sleek aesthetics with advanced functionality.

This kiosk includes features like the off set monitor to provide easier wheelchair access and a tilt bracket to assist those of different heights. The STORM Audio NAV system and the keyboard are seamlessly integrated to improve the user experience for those with low vision.

This updated kiosk not only enhances access to the barcode and ID scanner, but it was also designed and engineered to deliver better value.

## ELEVATING THE PATIENT EXPERIENCE

Self-service kiosks like the Chicago improve profitability and reduce operational costs, allowing staff to focus more on patient care. This results in a win-win situation for both patients and healthcare providers.

### PATIENT BENEFITS

- Faster check-in vs. registration desk
- Reduced time spent in line
- Enhanced privacy and experience
- Improved accessibility for all users

### HEALTHCARE PROVIDER BENEFITS

- Streamlined check-in process
- Reduced front desk congestion
- Improved accuracy
- Optimized staffing and cost-effective operations
- Enhanced billing collections and secure payment handling
- Increased patient and employee satisfaction

Healthcare Check-in Kiosks are an efficient, secure, and self-service option for providers looking to streamline administrative tasks while enhancing the patient experience. They are ideally suited for deployment in various healthcare settings, including:

Hospital Lobbies    Pharmacies    Admitting Departments    Medical Clinics

# CHICAGO HEALTHCARE CHECK-IN KIOSK

## MODERN ADA FOR ALL

Height Adjustable (HA)



Freestanding (FS)



The Chicago kiosk was created to provide a lighter kiosk that better addresses ADA compliance. While most organizations have delivered on the height and reach requirements to address ADA, the experience for low vision and blind users fell short. This model includes options to address that by including a keyboard and Storm device as recommended by ADA experts.

The Chicago Kiosk has the following features:

- Improved visibility and easier access to the ID and bar code scanners.
- Inclusion of a keyboard to ensure a better user experience for the visually impaired.
- Integration of the STORM Audio NAV device into the design.
- Tilt bracket to adjust monitor and camera to improve access and performance.
- Anti-glare screens are also available.

The [Austin Healthcare Check-in](#) is also available.

For the latest in hardware considerations and workflow adjustments, please consult [Welcome Accessibility](#). (This link is accessible via your EPIC UserWeb login.)



Desktop (DT)



# REDEFINING SELF-SERVICE TECHNOLOGY FOR HEALTHCARE CHECK-IN

These feature-packed kiosks are designed modularly to ensure the kiosks can perform a wide variety of functions necessary across any healthcare environment.

## STANDARD SPECS

- 22" PCAP Touchscreen with Privacy Filter with Micro Form Factor PC
- Height-adjustable from 48" to 59.8"
- ID Scanner
- Barcode Imager
- Web Camera
- Payment Device Options
- No-effort paddle switch to activate lift and lowering (on HA model only)
- Braille device labels
- Durable power coat paint finish
- 16 Gauge galvanized steel
- Security locks
- Internal 6-outlet power strip
- Topple resistant base plate with ability to bolt to ground

The Chicago model supports several peripheral devices. Our team can help you determine what options might be best for your needs.

## OPTIONAL COMPONENTS

- 22" PCAP All-in-One computers
- UV-C sanitizing light system
- Magstripe reader
- RFID/NFC devices
- STORM Audio NAV device
- Keyboard
- WiFi Antenna
- Anti-glare Screen
- Privacy screen
- Antimicrobial paint
- Antimicrobial film



# A CLOSER LOOK

## AT CHICAGO HEALTHCARE CHECK-IN KIOSKS

### HEIGHT-ADJUSTABLE

#### DIMENSIONS

- Width: 25.5"
- Height: Adjusts from 48" to 59.8"
- Depth: 23"
- Base plate: 25.5"w x 23"d

#### ADDITIONAL INFORMATION

- Weight: 150 lb.\*
- Power: Standard Outlet
- Electrical Draw: less than 5 amp

\*Weights are approximate and may vary slightly with changes in peripherals.

### DIMENSIONS WITH BASE IN LOWEST POSITION

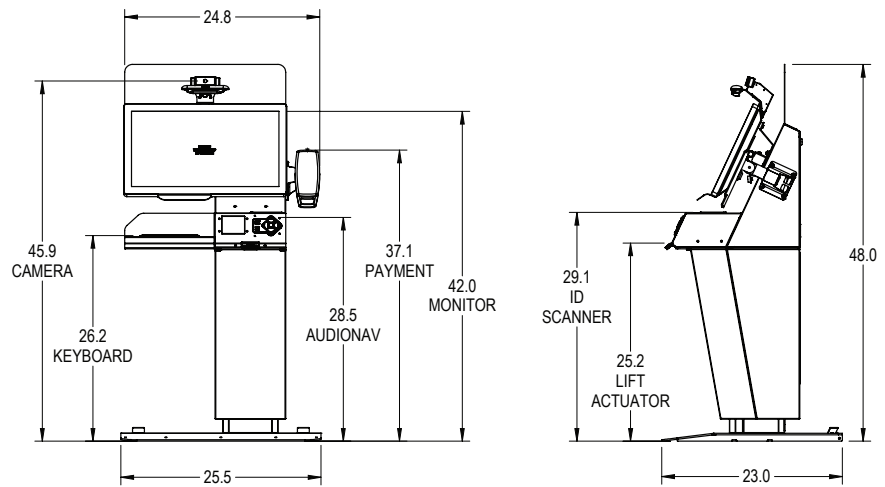

### DIMENSIONS WITH BASE IN HIGHEST POSITION

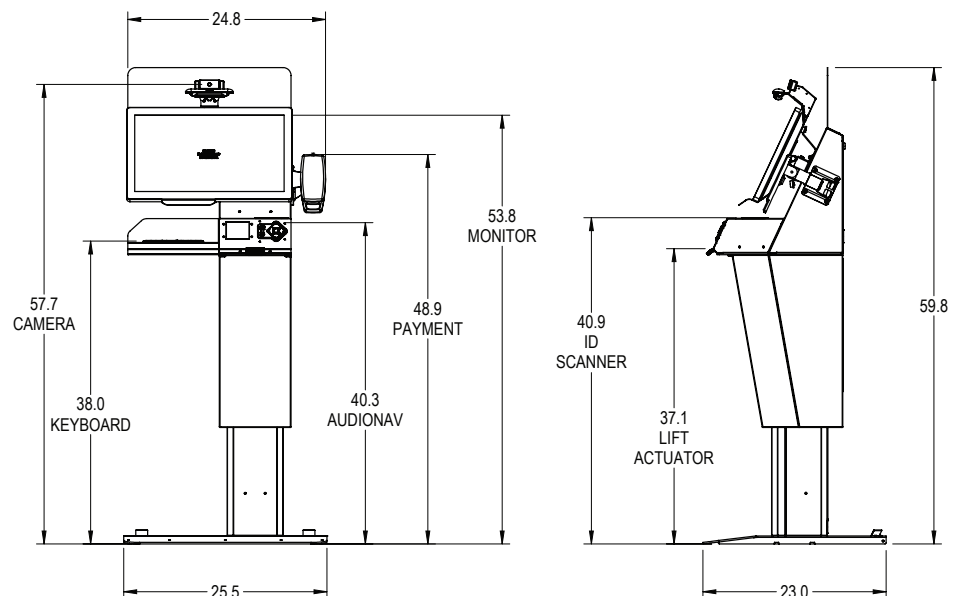

# A CLOSER LOOK

## AT CHICAGO HEALTHCARE CHECK-IN KIOSKS

### FREESTANDING

#### DIMENSIONS

- Width: 24.8"
- Height: 54"
- Depth: 21"
- Base plate: 23"w x 21"d

#### ADDITIONAL INFORMATION

- Weight: 120 lbs.\*
- Power: Standard Outlet
- Electrical Draw: less than 5 amp

\*Weights are approximate and may vary slightly with changes in peripherals.

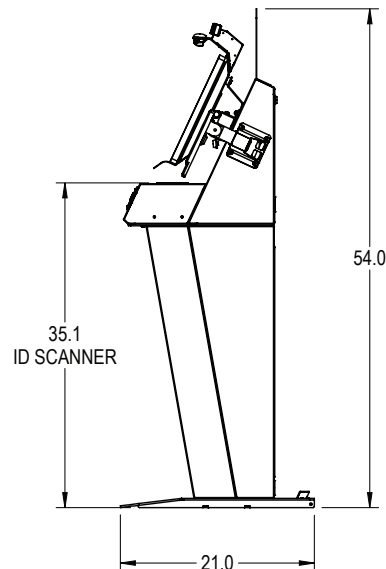
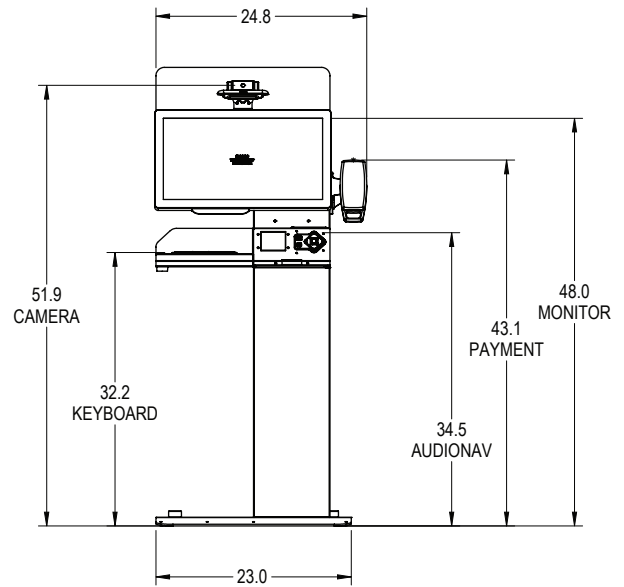

# A CLOSER LOOK

## AT CHICAGO HEALTHCARE CHECK-IN KIOSKS

### DESKTOP

### DIMENSIONS

- Width: 24.8"
- Height: 24"
- Depth: 16.4"
- Base plate: 20.5"w x 16.4"D

### ADDITIONAL INFORMATION

- Weight: 60 lbs.\*
- Power: Standard Outlet
- Electrical Draw: less than 5 amp

\*Weights are approximate and may vary slightly with changes in peripherals.

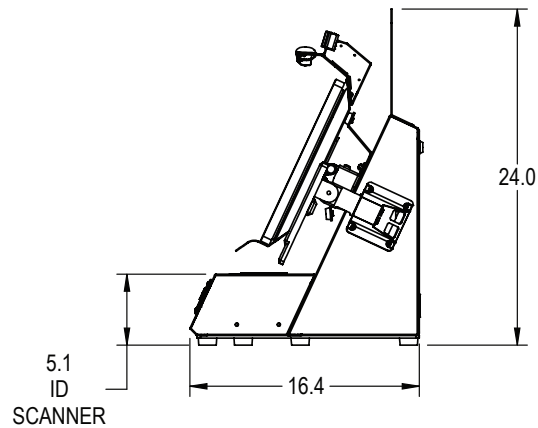
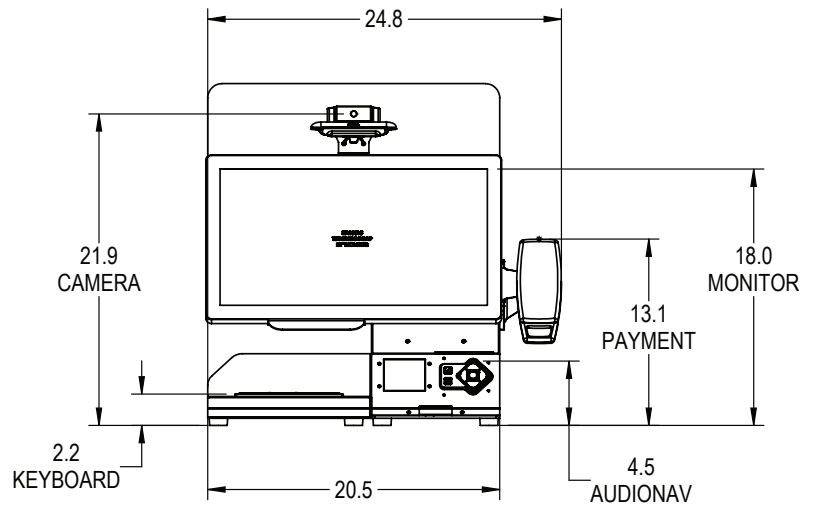

### EXPERIENCE MATTERS

Olea has the self-service applications your Healthcare facility needs to enhance the patient experience and the bottom line.

