

# TAMPA KIOSK

## DATA SHEET ROBUST AND RELIABLE

Experience streamlined efficiency with our cutting-edge kiosk, engineered specifically for truck driver check-ins. This innovative solution not only enhances traffic flow within your yard but also elevates overall efficiency.

Designed for versatility, our kiosk offers in-lane services, enabling drivers to check in without leaving their vehicles—optimizing yard space and bolstering driver safety.

Enhance your supply chain operations and fortify site security with self-service kiosks.

## BRINGING EXCELLENCE TO THE USER EXPERIENCE

- Driver Check-in / Yard Management
- Smart Bill of Lading
- Load Weigh Scales



# TAMPA KIOSK

## KEEPING IT SIMPLE

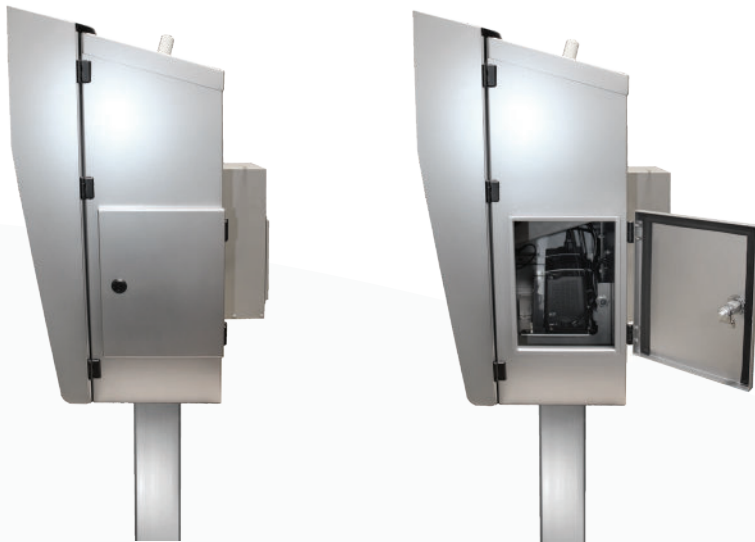

This outdoor kiosk is a workhorse when it comes to yard management.

The Tampa is perfect for deploying in-lane. With its robust design, drivers can easily pull up alongside the unit, confirm identification, and take care of any paperwork.

The 15" monitor provides an interactive experience while maintaining a functional and clean modular design.

- Pole mounting to accommodate various vehicle heights for in-cab check-in.
- Can be equipped with an intercom system to communicate with staff.
- Side access door to permit kiosk servicing while truck is in-lane.
- Add an optional I/O control for gate or door access.

A simple outdoor unit that is perfect for automating check-in, validating driver identification, and confirming load details.



# A CLOSER LOOK

## AT TAMPA

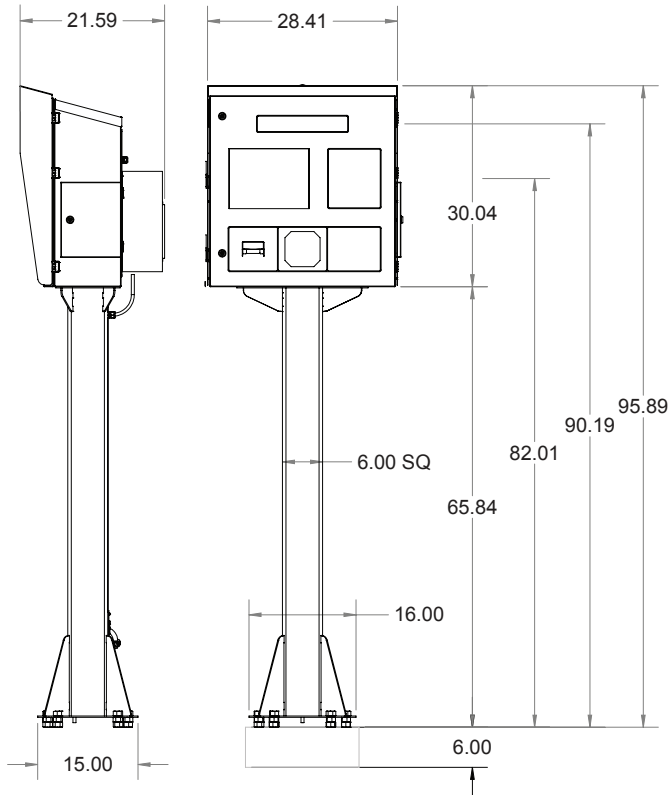

### DIMENSIONS

#### Tall

- Width: 28.41"
- Height: 95.89"
- Depth: 21.59"

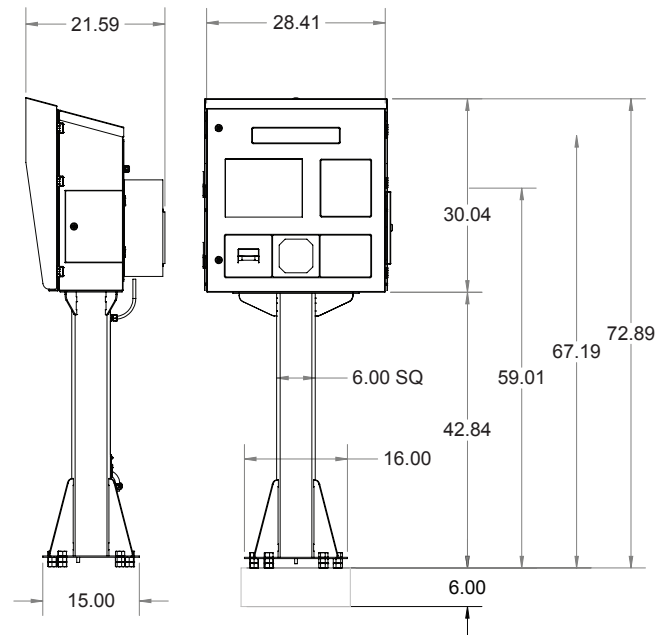

### DIMENSIONS

#### Short

- Width: 28.41"
- Height: 72.89"
- Depth: 21.59"

### STANDARD SPECS

- 15" PCAP multi-touch touchscreen
- High Bright LCD
- 800 mm receipt printer
- Powder-coat painted stainless steel
- Security locks
- Internal 6-outlet power strip

# REDEFINING SELF-SERVICE TECHNOLOGY FOR THE OUTDOORS

## OPTIONAL COMPONENTS

The Tampa kiosk is extremely modular and can support several optional peripherals. Our team can help you determine what options are best for your needs.

- Windows or Android OS available
- VOIP teleconference intercom box with noise cancellation
- RFID reader for badge scanning
- Barcode Scanner
- Printer
- HD Web Camera, infrared option for nighttime capabilities
- I/O switch control for gate and door access
- Barcode Reader/Scanner option
- RFID Reader



## EXPERIENCE MATTERS

Olea has the self-service applications your organization needs to enhance the user experience and the bottom line.

We've deployed more than 50,000 kiosks across more than 15 countries.

